



VirCru

Remote Dual DC Control Switch

CONTENTS

SECTIONS

- 1 VIRCRU DC CONTROL SWITCH SUMMARY
- 2 INSTALLATION GUIDE
- 3 THE VIRCRU APP
- 4 DON'T FORGET
- 5 WE'RE HERE TO HELP

1. VIRCRU REMOTE DUAL DC CONTROL SWITCH SUMMARY

The VirCru DC Control Switch allows you to remotely control DC electrical appliances up to a total of 10 Amps, e.g. heating and lighting.

For instance, you can ensure your fridge is at the perfect temperature before you arrive on board, or that the heating is warm and toasty.

Once installed correctly, you will be able to turn these appliances on and off via the VirCru App as well as by the manual switch if needed (If the appliance is switched off remotely the manual switch will need to be toggled to OFF then ON to switch the appliance back on again).

The DC Control Switch can be wired either before or after the Battery Isolator. Pre-installation consideration should be made as to your installation requirements, taking into account the following:

- **Option 1** - 'Before the Isolator'. This will enable DC appliances wired to the unit to operate when the Battery Isolator is on or **OFF allowing** you to switch an appliance when away from the boat without the need to leave the Isolator switched on permanently. E.g. Fridge, heater, lights etc.
- **Option 2** - 'After the Isolator'. This will only allow DC appliances wired to the unit to operate when the Battery Isolator is **ON, preventing** you from switching an appliance when away from the boat when the isolator is switched off.

We recommend using a marine electrician for the installation of the VirCru DC Control Switch.

If you require remote control of a switch greater than 10 Amps, a relay can be used.

Included in your VirCru DC Control Switch Pack:

- VirCru DC Control Switch
- Screw Terminal Plug
- Mounting Screws (x2)
- This Guide

Before installing, we recommend registering the Sensor on the VirCru App by scanning the QR code. This functionality can be found in the “Settings” tab.

If any of these items are missing from your box, please contact VirCru customer service at:

(+44 (0)1386 800360) or

customer.services@vircru.com

2. INSTALLATION GUIDE

Safety Precautions

Please ensure to:

- Follow all installation instructions
- Only carry out tasks in which you are competent. We recommend using a marine electrician for the installation of the VirCru DC Control Switch.
- Make full consideration of the environmental conditions and hazards during installation
- Avoid drilling into any Hub or Tag enclosures, due to the risk of piercing/exploding batteries
- Take care to ensure correct polarity on all wired connections.

The DC Control Switch is secured using the two screws provided and installed by breaking into the relevant wiring. Consideration should be given to the location of the DC Control Switch – although controlled wirelessly, the switch will require wired power from the battery and wire feed to the item(s) being switched.

N.B. – it is essential that the in-line fuse is positioned as close to the battery as possible.

Wiring Diagrams of DC Switch Installation

Wired before isolator on circuit 1 Wired after isolator on circuit 2

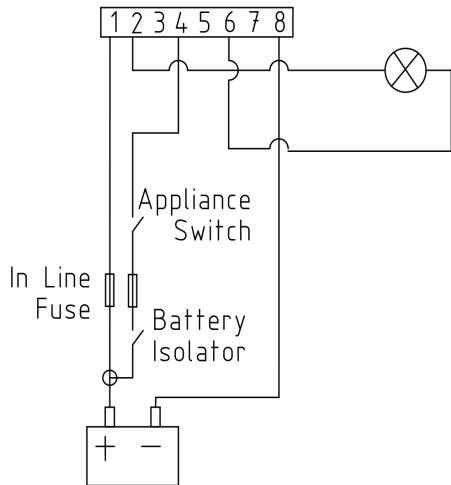

Fig 1

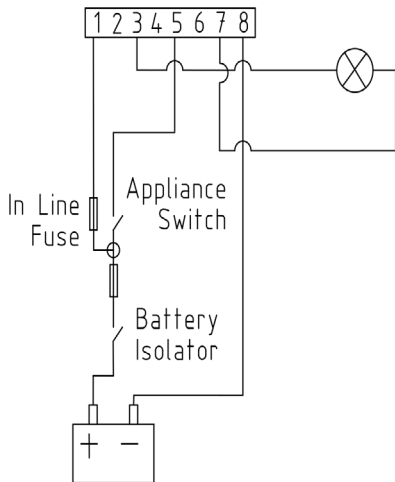

Fig 2

Figure 1: Shows a 'Before Isolator' connection using Output and Input '1'.

Figure 2: Shows an 'After Isolator' connection using Output and Input '2'.

The OUT 1- (0V Negative) and the OUT 2- (0V Negative) terminals are optional. These may be useful for a new installation (rather than breaking into an existing installation) where a pair of wires can be run from the DC Control Switch to the appliance.

Pin Out Diagram

1	2	3	4	5	6	7	8
---	---	---	---	---	---	---	---

1. Battery +
2. Out 1 +
3. Out 2 +
4. Switch 1
5. Switch 2
6. Out 1 -
7. Out 2 -
8. Battery -

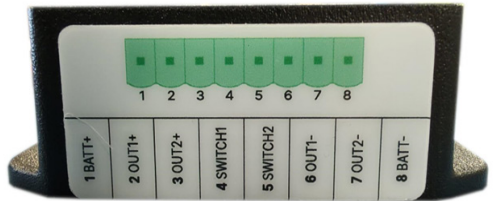
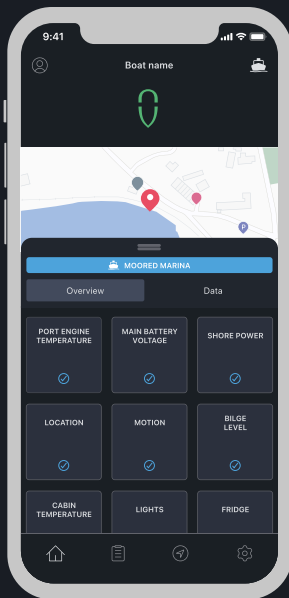

Fig 3

3. The VirCru App



How to Install your VirCru App

The VirCru App is supported by software versions iOS 13 and above on iPhone, and versions 5.0 (Lollipop) and above on Android. Ensure your mobile has these software versions installed before downloading the VirCru App.

To download the VirCru App (iPhone):

- Unlock your phone and navigate to the 'App Store'
- Type "VirCru" in the search bar
- Click "Get" by the VirCru logo icon
- Once authorised, the VirCru App will Appear on your iPhone's home page.

To download the VirCru App (Android):

- Unlock your phone and navigate to the 'Google Play Store'
- Type "VirCru" in the search bar
- Click "Install" by the VirCru logo icon
- Once authorised, the VirCru App will Appear on your Android device's home page.

The VirCru App features a simple and intuitive interface to display and personally configure the data provided by the VirCru Hub, Sensors and Products installed on your boat.

The VirCru App main dashboard gives you an overview of all data, which can be explored in more detail if required. It also includes an inventory system for all the other products and services related to your boat, from insurance details, documents and renewal dates through to life jacket servicing.

For more information on configuring and using the VirCru App, please refer to our comprehensive App User Guide available at www.vircru.com. This document provides detailed analysis of the setup, features and functionality of our App in one place, and is constantly evolving as we add new features and technology to our interface.

4. DON'T FORGET

- Check your Hub and Sensors every few months to ensure they are working properly
- It is always best to mount your equipment on flat and smooth surfaces. Before fixing adhesive pads, ensure you clean your surfaces using the alcohol wipes provided
- If you require any assistance with installation, contact a professional marine electrician or a member of the VirCru team.



VirCru is your virtual crew – always onboard and always connected to you.

5. We're Here to Help

Phone or email our UK-based team for any technical support, product information or sales advice you need using the contact details below:

customer.services@vircru.com

We aim to respond to all email enquiries within 24 hours (Mon-Fri)

+44 (0)1386 800360

Our phone lines are open during working hours for enquiries, and we will aim to respond to your call within 24 hours (Monday-Friday).

Other VirCru Products

VirCru offers a comprehensive range of products to ensure you can be in touch with your boat from wherever you are. To view our full range of Hubs, Tags, Sensors, Alarms and more, visit <https://www.vircru.com/>.



If you need any help with your VirCru installation or
App set-up please email: customer.services@vircru.com